

RMS-11
MACHINED

SIZE
A

8-21-08



The Right Connection™

**MANUFACTURING
DRAWING**

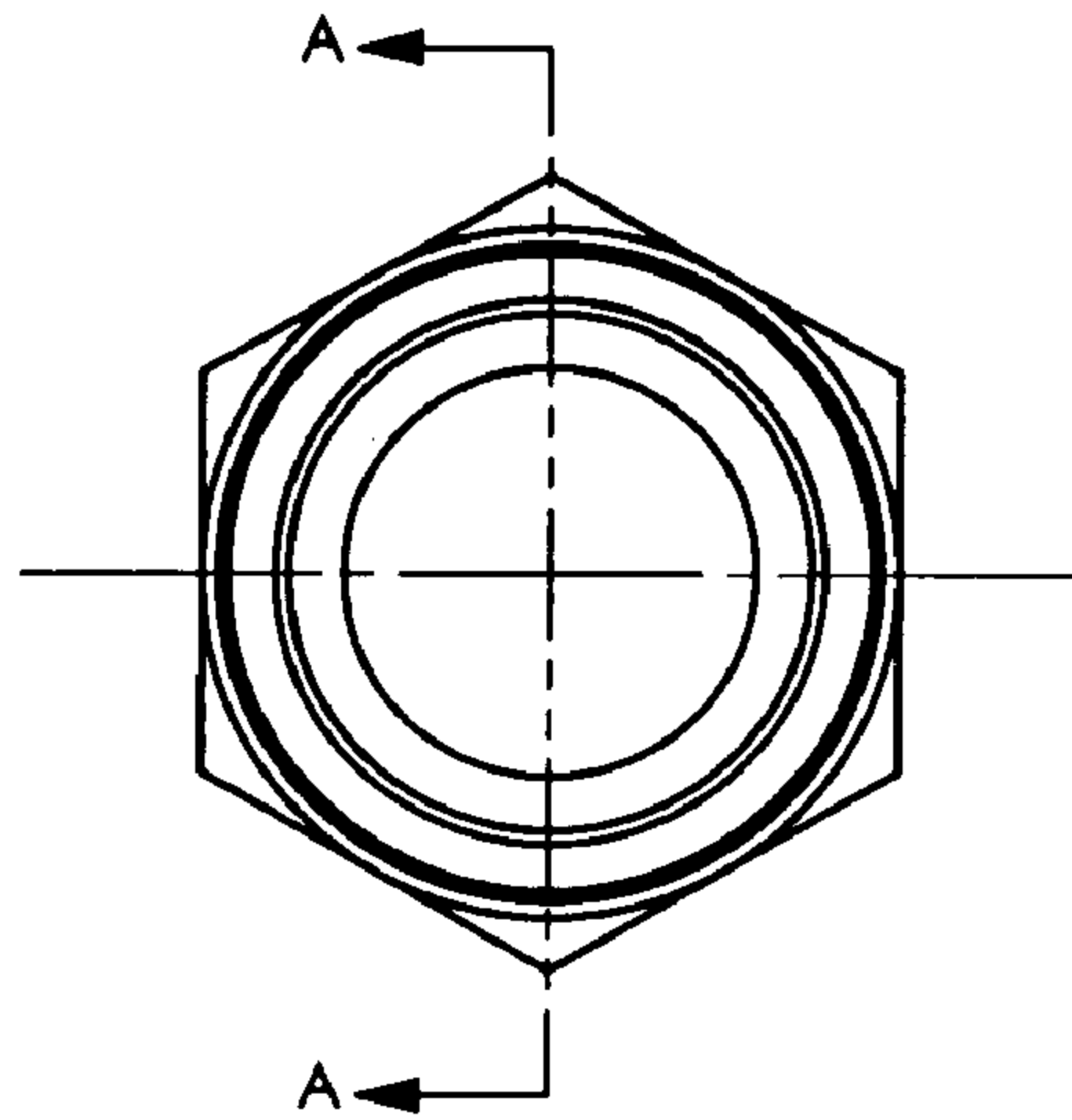

1-11 1/2 NPT
MAJOR DIA 1.660/1.650
(THREAD TO GAGE FLUSH
OR ONE THREAD SMALL)

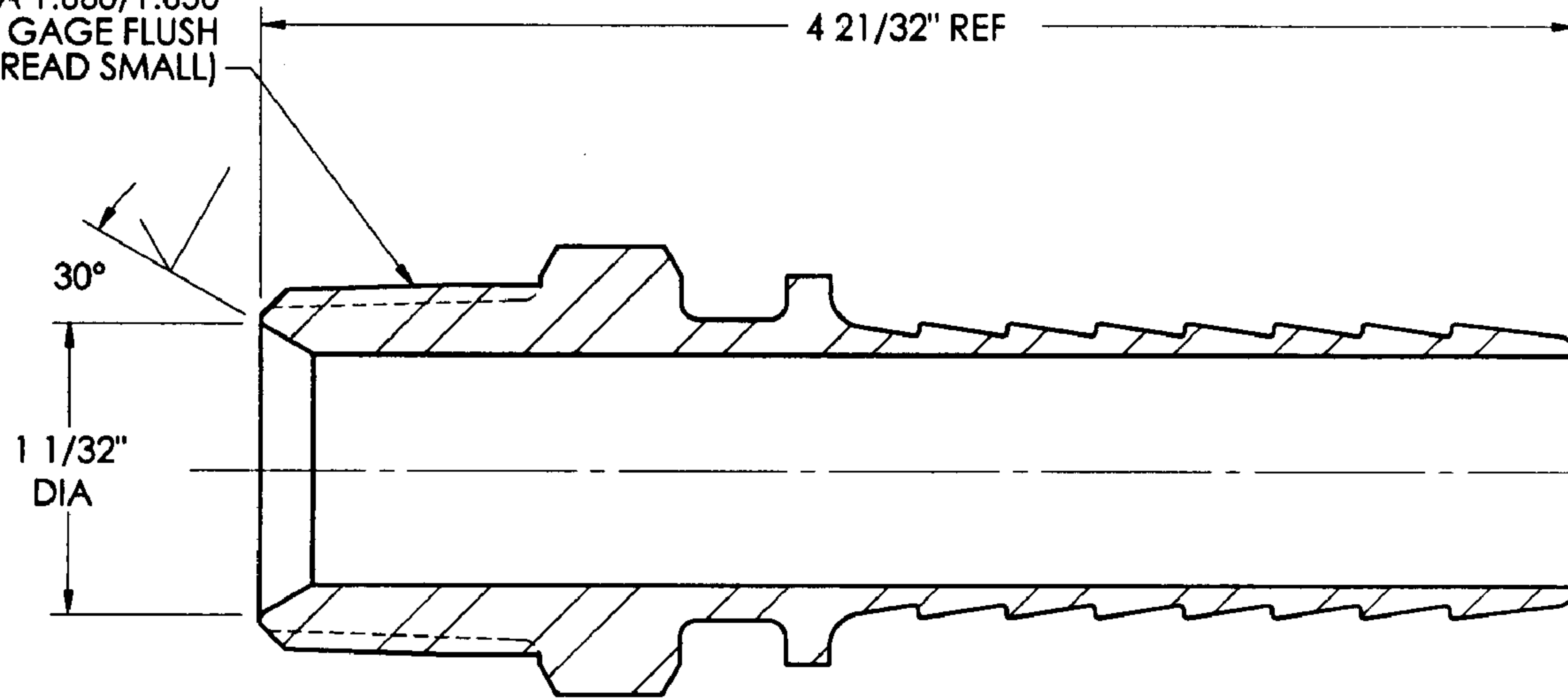

SECTION A-A

NOTES:
1) BREAK ALL SHARP EDGES.

<p>This drawing is owned by Dixon Valve & Coupling Co. and shall be returned upon demand. It is loaned on condition that it shall not be copied or reproduced or submitted to others without the owners consent. In accepting it subject to this condition the recipient further agrees that this drawing or any design detail or concept disclosed herein shall not be used in any way detrimental to or in competition with the owner. If the recipient does not agree to the terms of this agreement they shall return this drawing immediately.</p>					
		<p>TOLERANCES UNLESS NOTED</p>		<p>DIXON VALVE & COUPLING CO. U. S. A.</p>	
		<p>DECIMAL ± .005 FRACTION ± 1/64 ANGLE ± 1°</p>			
		<p>SCALE: 1:1 UNLESS NOTED</p>		<p>TITLE 1" "BOSS" MALE STEM</p>	
		<p>DRWN BY: JON W 07/05/00</p>		<p>ENG CHK: <i>CR</i></p>	
		<p>MFG CHK: <i>JLM</i></p>		<p>APPROVAL: <i>CR</i></p>	
<p>D JLW 07/06 00</p>		<p>REVISED & REDRAWN</p>		<p>MAT'L: 316 STAINLESS STEEL INVESTMENT CASTING CF-8M ASTM# A743</p>	
<p>REV BY DATE</p>		<p>DESCRIPTION</p>		<p>RMS-11 MACHINED</p>	
<p>ER#</p>				<p>SIZE A</p>	

FOLDER#