

RB-4

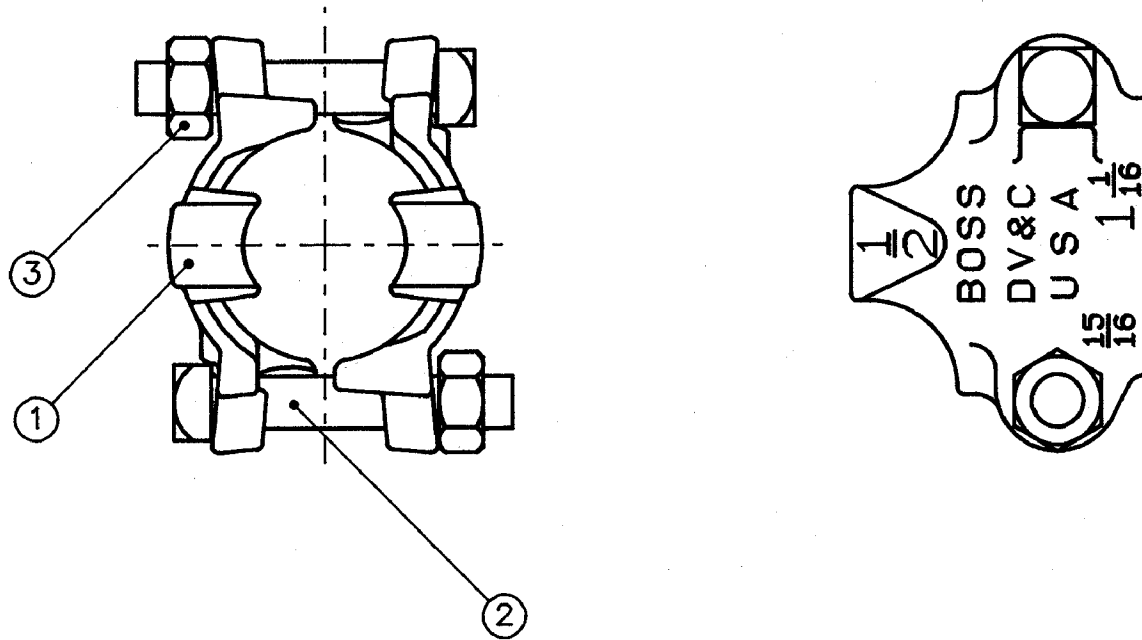

CUSTOMER DWG.

NOTES:

- 1) MAX. RECOMMENDED TORQUE IS 12 FT-LBS.
- 2) CLAMP FITS HOSE O.D. FROM 15/16" TO 1.1/16".

ITEM	PART #	DESCRIPTION	MATERIAL	QTY
3	RMN-5	5/16-18 UNC HEX NUT	316 STAINLESS STEEL	2
2	RMB-5150	5/16-18 UNC x 1.1/2" LENGTH SQ. HEAD BOLT WITH 1" THREAD LENGTH	316 STAINLESS STEEL	2
1	RB-4	1/2" BOSS CLAMP	316 STAINLESS STEEL	2

		TOLERANCES (UNLESS NOTED)		DIXON VALVE & COUPLING CO. U. S. A. TITLE: RB-4 BOSS CLAMP ASSEMBLY DRWN. <i>MDS</i>   CHKD. <i>CW</i>   APPR. <i>AK</i> 03/12/91   3-12-91   3-12-91	
		DECIMAL± _____			
		FRACTION± _____			
		ANGLE± _____			
REV.	BY	DATE	DESCRIPTION	MAT'L SEE B/M	
				RB-4	

