

GF201

CUSTOMER DWG

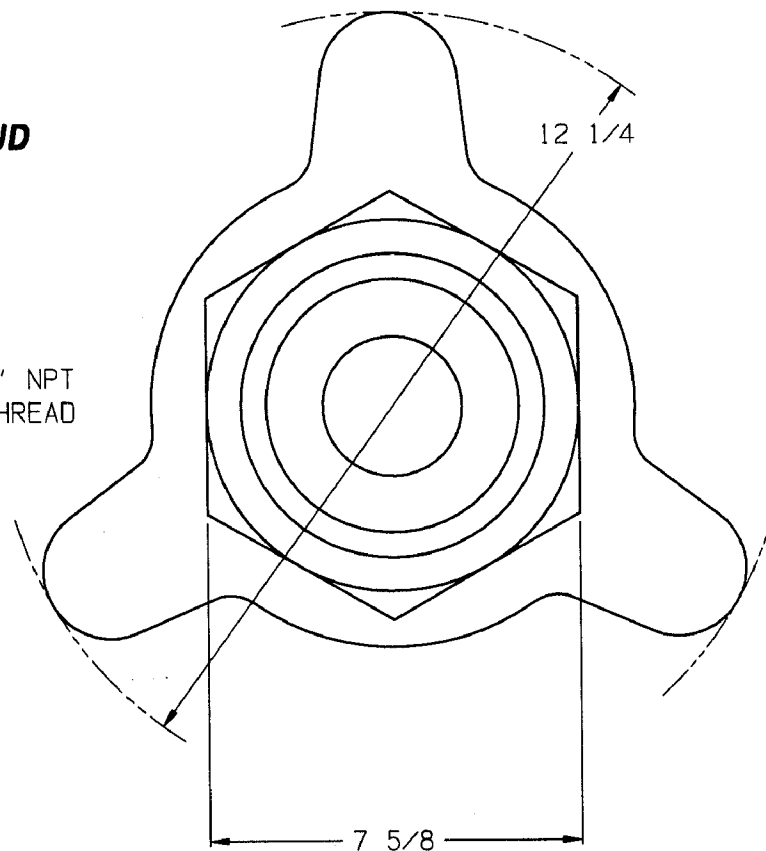
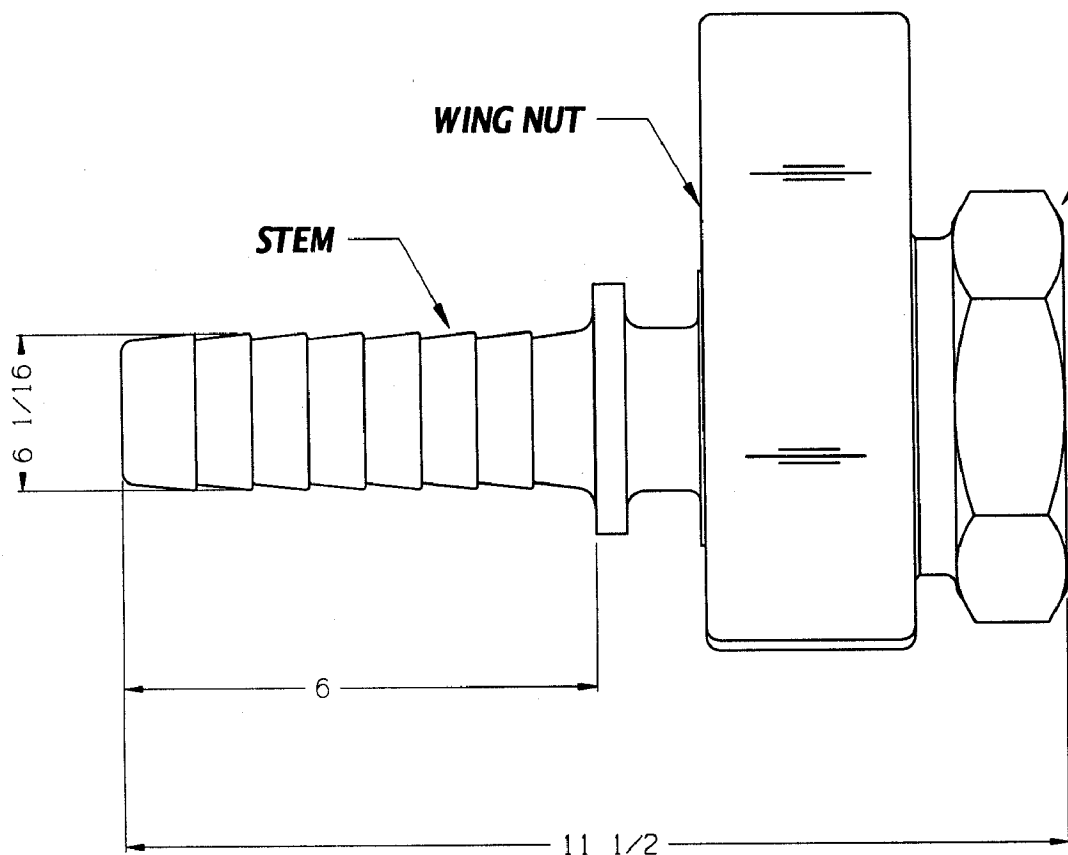

MAT'L:

STEM - MALLEABLE IRON ASTM# A74
WING NUT - MALLEABLE IRON ASTM# A47
SPUD - DUCTILE IRON ASTM# A536

CUSTOMER DWG



AGREEMENT TO MAINTAIN CONFIDENTIALITY

This drawing is owned by Dixon Valve & Coupling Co. and shall be returned upon demand. It is loaned on condition that it shall not be copied or reproduced or submitted to others without the owners consent. In accepting it subject to this condition the recipient further agrees that this drawing or any design detail or concept disclosed herein shall not be used in any way detrimental to or in competition with the Owner. If the recipient does not agree to the terms of this agreement, they shall return this drawing immediately.

DIXON VALVE & COUPLING CO.
U. S. A.

TITLE

6" 'BOSS' COUPLING w/FEMALE SPUD

DRAWN BY:

Diane

12/01/98

CHECKED BY:

Mike
12-1-98

APPROVAL:

[Signature]

MAT'L

SEE ABOVE

GF201