

XXX

CUSTOMER DWG.  
8-7-08

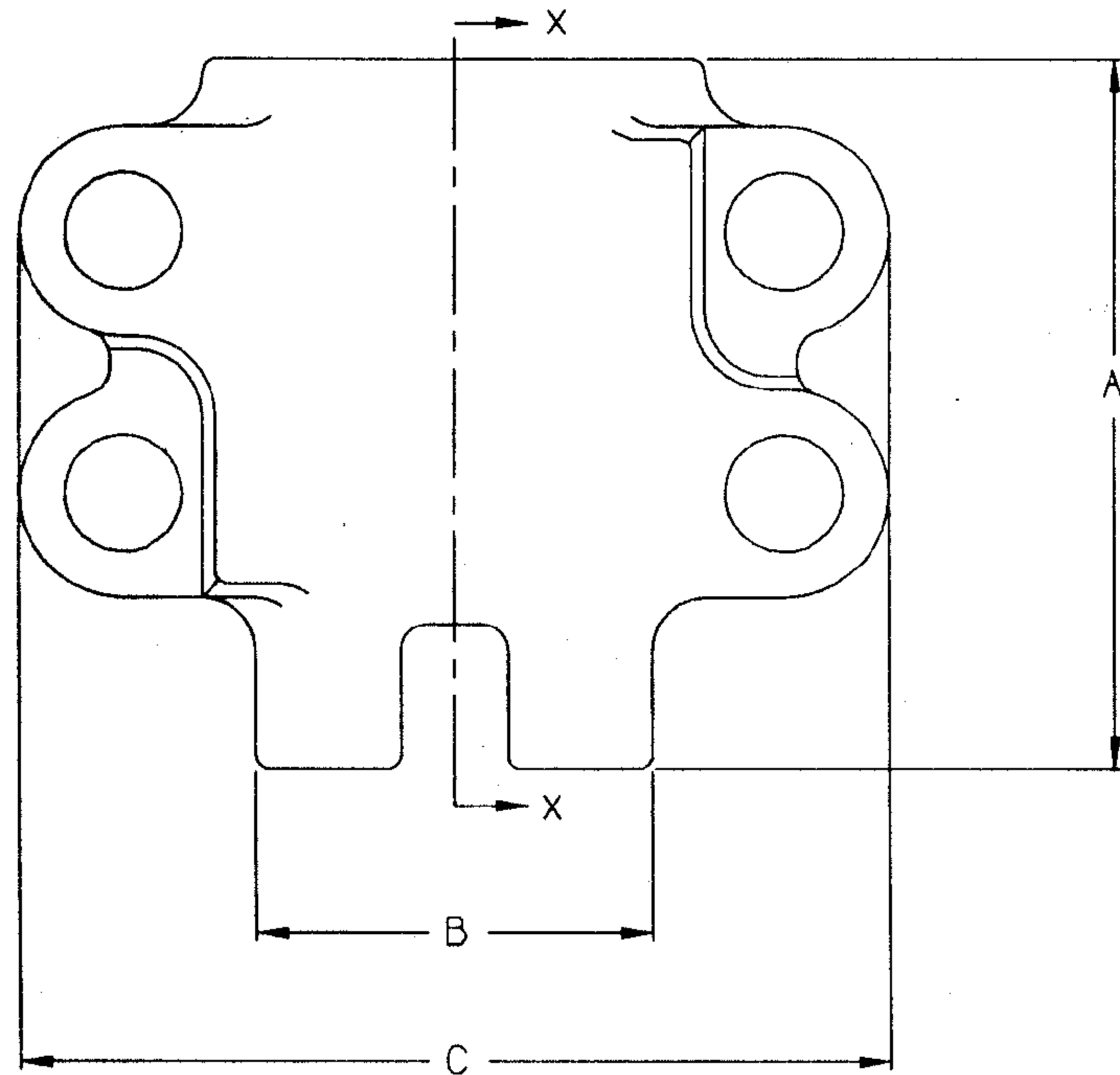

968	1/2"	29/32	1 1/32	1 11/16	15/32	2 1/16	1/8	6
156	1"	1 13/32	1 9/16	2 21/32	1 5/8	3 3/16	5/32	21
187	1 1/4"	1 11/16	1 7/8	3 1/16	2 1/32	3 9/16	5/32	21
206	1 1/4"	1 7/8	2 1/16	2 29/32	2 1/8	3 21/32	7/32	21
212	1 1/2"	2	2 1/8	3 3/8	2 13/32	4	7/32	21
225	1 1/2"	2 1/16	2 1/4	3 5/8	2 1/4	4	9/32	40
250	2"	2 1/4	2 1/2	3 13/16	2 7/16	4 3/16	5/16	40
275	2"	2 1/2	2 3/4	3 7/8	2 3/4	4 1/2	1/4	40
306	2"	2 3/4	3 1/16	4 1/8	3 1/8	5 1/8	5/16	60
350	2 1/2"	3 1/16	3 1/2	4 1/8	3 15/32	5 3/4	11/32	60
375	2 1/2"	3 1/2	3 3/4	4 15/32	3 24/32	6 1/8	11/32	60
401	3"	3 3/4	4	4 23/32	3 31/32	6 1/2	9/32	150
418	3"	4	4 3/16	4 29/32	4 3/8	7	3/8	200
450	3"	4 3/16	4 1/2	5 3/16	4 11/16	7 1/2	3/8	200
<b>PART NO.</b>	<b>HOSE SIZE</b>	<b>FROM HOSE</b>	<b>TO HOSE O.D.</b>	<b>A</b>	<b>B</b>	<b>C</b>	<b>D</b>	<b>TORQUE FT-LBS</b>

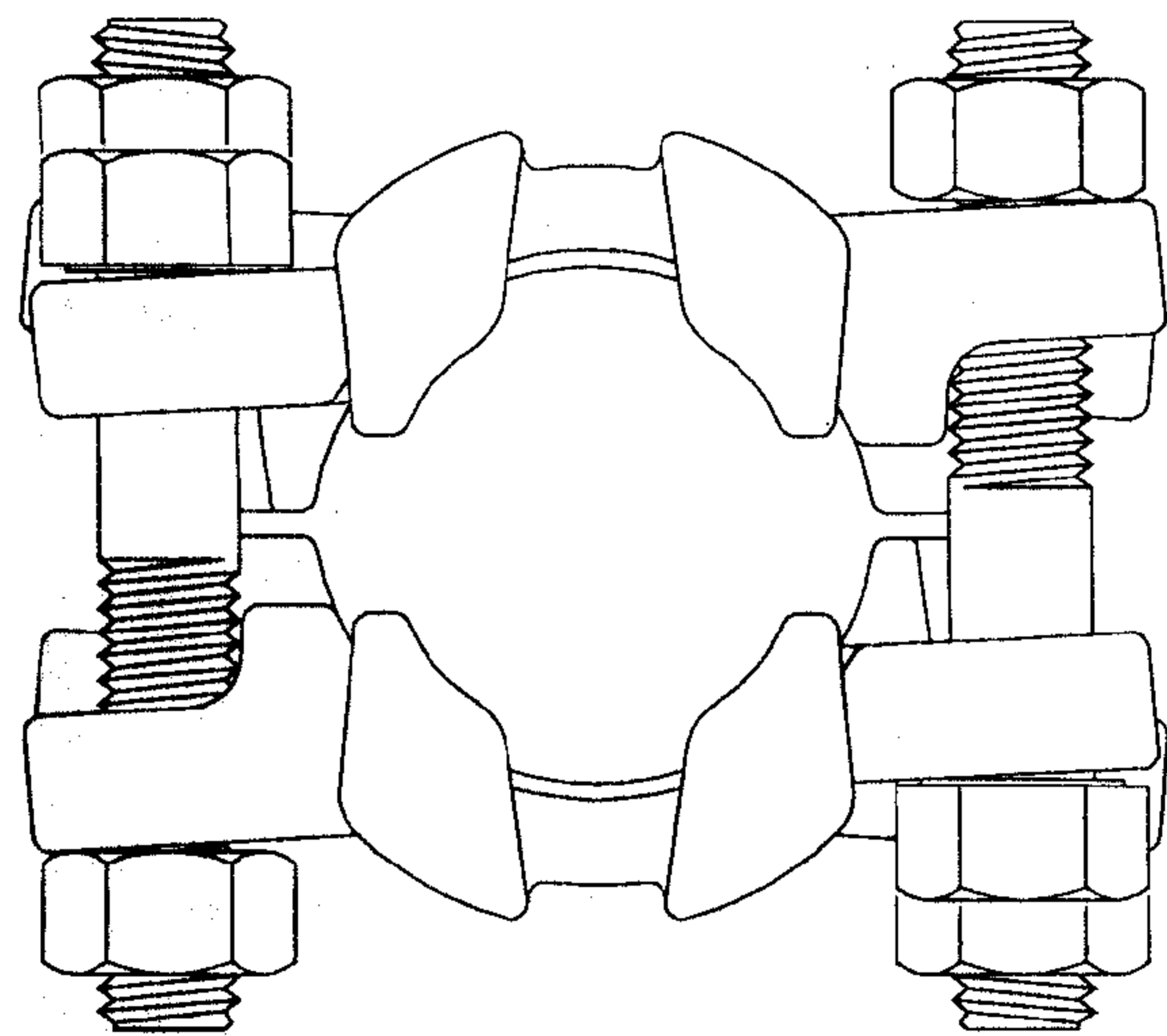

AGREEMENT TO MAINTAIN CONFIDENTIALITY

This drawing is owned by Dixon Valve & Coupling Co. and shall be returned upon demand. It is loaned on condition that it shall not be copied or reproduced or submitted to others without the owners consent. In accepting it subject to this condition the recipient further agrees that this drawing or any design detail or concept disclosed herein shall not be used in any way detrimental to or in competition with the Owner.

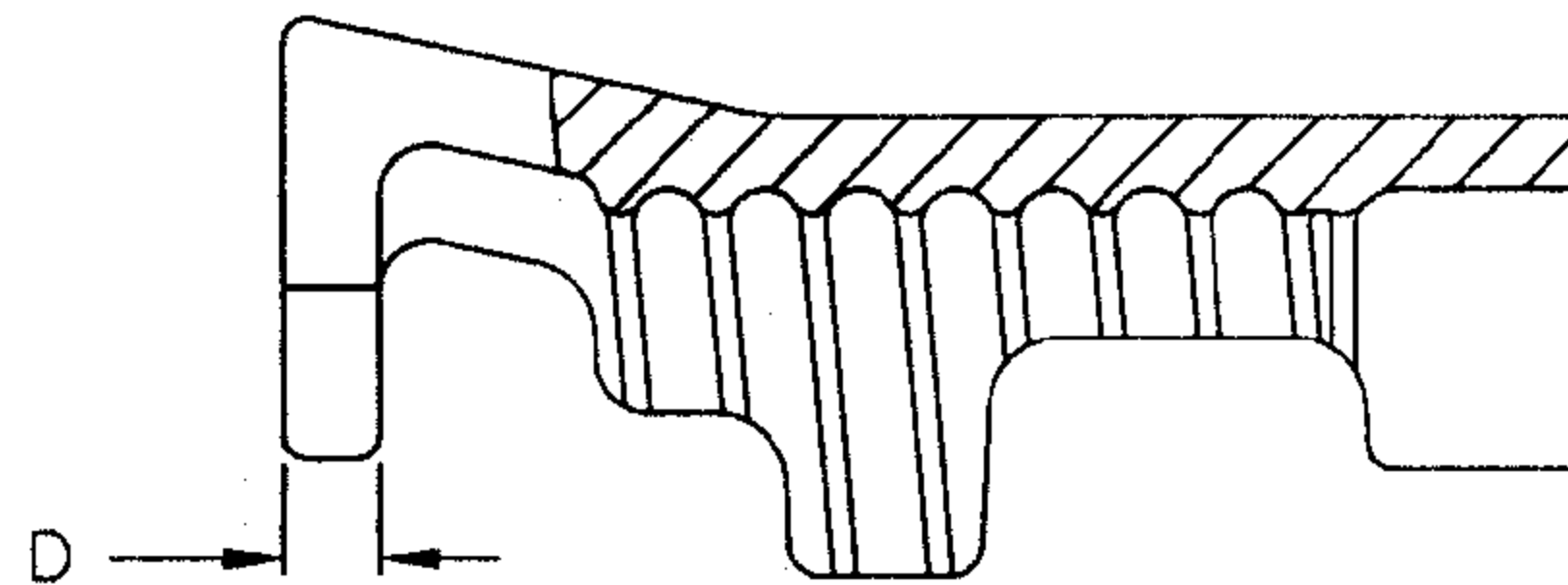

SECTION X-X



The Right Connection™

ZINC PLATE

CUSTOMER DWG.

DIXON VALVE & COUPLING CO.  
U. S. A.

TITLE  
BOSS CLAMP  
4-BOLT TYPE; 4 GRIPPING FINGERS

SCALE:  
NOT TO SCALE

DRWN: *WD*  
8/23/96

APPROVAL:  
*Mike*  
8-27-96

MAT'L  
DUCTILE IRON

XXX